

Pedestrian stacker truck 0.8 ton

BT lifter

S-series

SHM080

SHL080

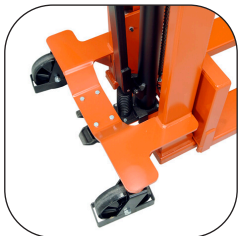

Stacker truck

Truck specifications					SHM080	SHL080
Identification	1.1	Manufacturer			Toyota	Toyota
	1.2	Manufacturer's type designation			SHM080	SHL080
	1.4	Operator type			Hand	Hand
	1.5	Load capacity/rated load	Q(t)	kg	800	800
	1.6	Load centre distance	c	mm	600	600
	1.8	Load distance, centre of drive axle to fork	x	mm	740	740
	1.9	Wheelbase	y	mm	1150	1150
Weight	2.1	Service weight		kg	255	295
	2.2	Axle load, with load, drive/castor/fork wheel		kg	150/390	150/390
	2.3	Axle load, without load, drive/castor/fork wheel		kg	40/95	40/95
Wheels	3.1	Steer/fork wheels. Nylon (N)			N/N	N/N
	3.2	Wheel size, front			Ø 200x50	Ø 200x50
	3.3	Wheel size, rear			Ø 75x75	Ø 75x75
	3.5	Wheels, number front/rear (x = driven wheels)			2/2	2/2
	3.6	Track width, front	b ₁₀	mm	650	650
	3.7	Track width, rear	b ₁₁	mm	400	400
Dimensions	4.4	Lift	h ₃	mm	1512	1512
		Lift height	h ₂₃	Mm	1600	1600
	4.5	Height, mast extended	h ₄	mm	1990	1990
	4.9	Height of tiller in drive position, min./max.	h ₁₄	mm	1290	1290
	4.15	Height, lowered	h ₁₃	mm	88	88
	4.19	Overall length	l ₁	mm	1675	1675
	4.20	Length to face of forks	l ₂	mm	525	525
	4.21	Overall width	b ₁ /b ₂	mm	770	770
	4.22	Fork dimensions	s/e/l	mm	55/160/1150	55/160/1150
	4.25	Width over forks	b _s	mm	540	540
	4.32	Ground clearance, centre of wheelbase	m ₂	mm	25	25
4.33	Aisle width for pallets 800 x 1200 lengthways	A _{st}	mm	1810	1810	
4.35	Turning radius	W _a	mm	1150	1150	
Performance	5.2	Lift speed with/without load		m/s	—	0,04/0,06
	5.3	Lowering speed, with/without load		m/s	Controlable	Controlable
	5.11	Parking brake			Manual	Manual
Electric motor	6.2	Lift motor rating at S3 15%		kW	—	0.8
	6.4	Battery voltage, nominal capacity K5		V/Ah	—	12/110

Data in 6.2 - 6.5 are based on the largest standard battery
In other cases data are based on a basic standard design.

All data are based on table configuration. Other configurations may give other values.
Truck performance and dimensions are nominal and subject to tolerances.
Products and specifications are subject to change without notice.

Mast dimensions, mm

BT Ministacker			SHM080	SHL080
h_{23}	Lift height	mm	1600	1600
h_3	Lift	mm	1512	1512
h_4	Height, mast extended	mm	1990	1990

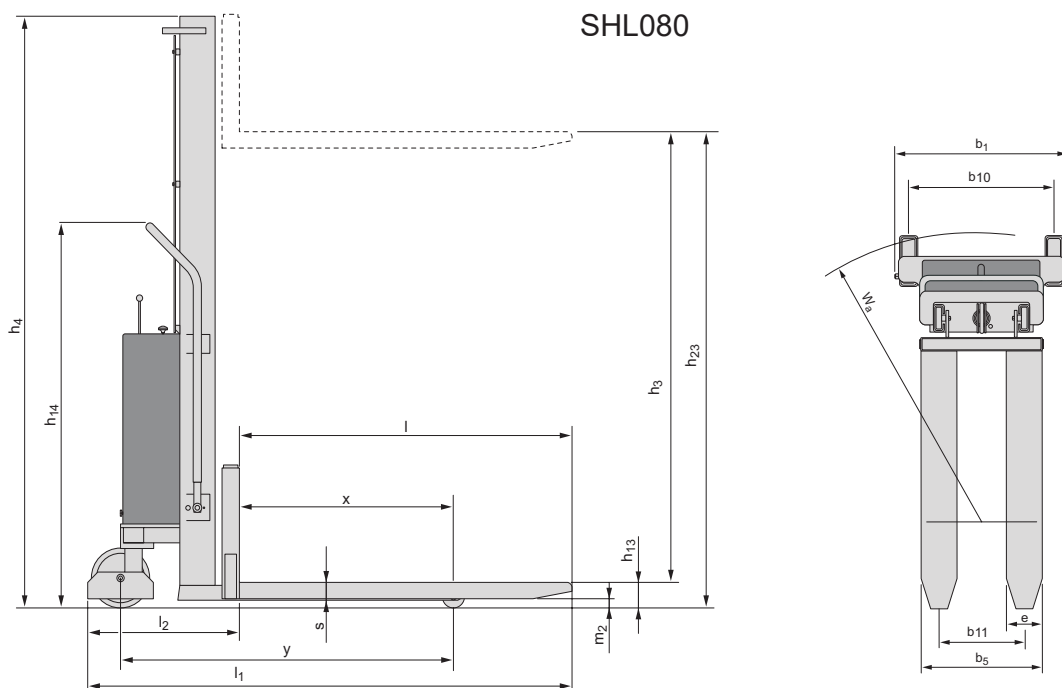
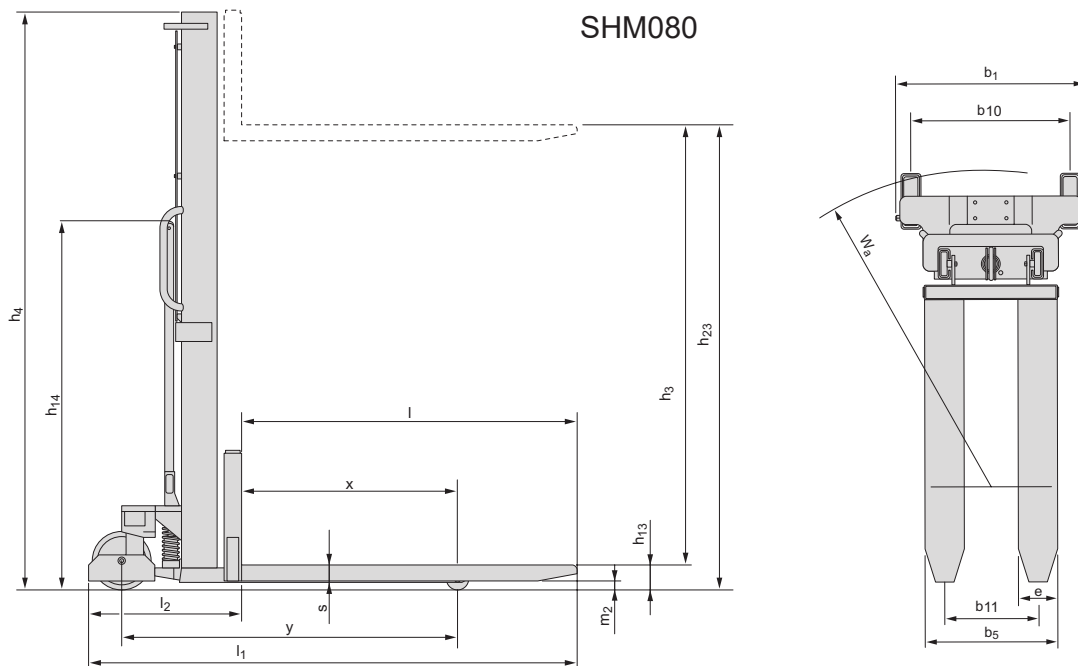

Truck features:

- Ideal for small stores and warehouse which require low-frequency and relatively low-level stacking.
- Ideal for block stacking or for use in racking.
- Available in manual or electric version. Maximum lift capacity 800 kg, maximum lift height 1600 mm.
- Clearview mast design allows exceptional visibility when pushing and placing/retrieving the load.
- Pinch protecting device at the steering wheels and parking brake allow safer working environment.
- Robust forks minimize bending down for heavy loads.
- The Ministacker can be equipped with wide support arms that straddle the load, allowing operation with a variety of difference pallet sizes.
- Wide Support arms can be combined with adjustable forks.

