

TOYOTA

TOYOTA MATERIAL HANDLING INTERNATIONAL



BT tyro

Powered pallet truck

The LHE150 is the perfect entry model for light electric pallet truck applications. Capacity of the truck is 1500 kg and it is equipped with li-ion technology for energy efficiency.

It combines the features of a powered pallet truck with the flexibility of a hand pallet truck.

Dimensional drawings

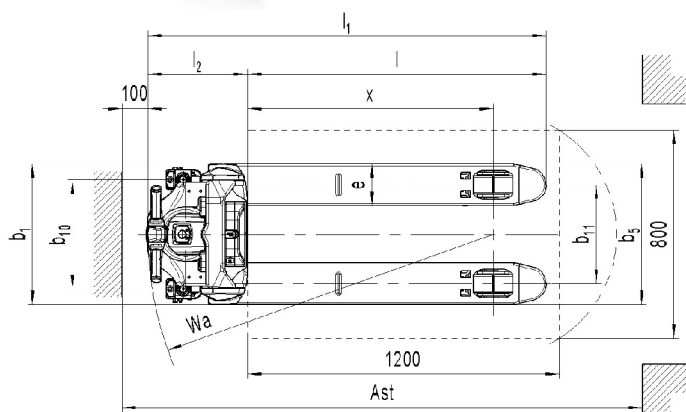
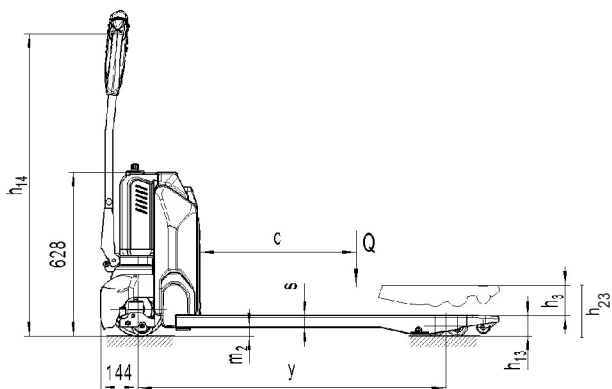

Features



Data sheet

Type sheet for industrial truck acc. to (EN 16796-2)				
Distinguishing mark	1.2	Manufacturer`s type designation		LHE150
	1.3	Power		Battery
	1.4	Operator type		Pedestrian / Stand
	1.5	Load Capacity / rated load	Q (t)	1.5
	1.6	Load centre distance	c (mm)	600
	1.8	Load distance, centre of drive axle to fork	x(mm)	947
	1.9	Wheelbase	y (mm)	1185
Weight	2.1	Service weight	kg	135 138
	2.2	Axle loading, laden front/rear	kg	635 / 1000 635 / 1000
	2.3	Axle loading, unladen front/ rear	kg	105 / 30 108 / 30
Tires, chassis	3.1	Tires		Polyurethane (PU)
	3.2	Drive wheel	Ø x w (mm)	Ø 210x70
	3.3	Fork wheels	Ø x w (mm)	Ø 80x93 (Boggie Ø 80x70)
	3.4	Castor wheels	Ø x w (mm)	Ø 80x30
	3.5	Wheels, number front/ rear (x=driven wheels)		1x +2/ 2 (1x +2/ 4)
	3.6	Tread, front	b10 (mm)	420
	3.7	Tread, rear	b11 (mm)	380 525
Dimensions	4.4	Lift height	h3 (mm)	115
		Lift height, height lowered combined	h23 (mm)	195
	4.9	Height of tiller in drive position min. / max.	h14 (mm)	700 / 1160
	4.15	Height lowered	h13 (mm)	80
	4.19	Overall length	l1 (mm)	1530
	4.20	Length to face of forks	l2 (mm)	380
	4.21	Overall width	b1 (mm)	540 685
	4.22	Fork dimensions	s/e/l (mm)	47 / 160 / 1150
	4.25	Width across forks	b5 (mm)	540 685
	4.32	Ground clearance, centre of wheelbase	m2 (mm)	33
	4.34	Aisle width for pallets 800X1200 lengthways	Ast(mm)	2000
Performance	4.35	Turning radius	Wa (mm)	1330
	5.1	Travel speed, laden/ unladen	km/h	4.3 / 4.5
	5.2	Lift speed, laden/ unladen	m/s	0.020 / 0.025
	5.3	Lowering speed, laden / unladen	m/s	0.05 / 0.04
	5.8	Gradeability, laden/ unladen	%	6 / 16
Motors	5.10	Service brake		Electromagnetic
	6.1	Drive motor rating S2 60min	kW	0.65
	6.2	Lift motor rating at S3 10%	kW	0.50
	6.3	Battery acc. to DIN 43531 /35 / 36 A, B, C, no		No
	6.4	Battery voltage, nominal capacity K5	V/Ah	24 / 20
	6.5	Battery weight (minimum)	kg	4.6
	6.6	Energy consumption acc. to EN 16796	kWh/h	0.18
	8.1	Type of drive control		DC - Speed Control
	8.4	Sound level at driver`s ear acc. to EN 12053	dB(A)	69

Product specification

The LHE150 compact design is perfect for light applications in confined areas such as retail, shops, warehouses and factories.

The LHE150 is ergonomic and can be manoeuvred effortlessly thanks to its tiller arm allowing it to work perfectly while on a vertical position.

This truck comes with a long life maintenance free Lithium-ion battery with quick and easy charging ensuring high availability and flexibility.



Specification	BT Tyro
Service weight including battery	123 kg
Load Capacity	1500 kg
Height, fork lowered	80 mm
Overall length	1530 mm
Overall width	540 mm
Turning radius	1330 mm
Travel speed, with/without load	4.6/4.8 km/h
Drive motor rating S2 60min	0.65 kW
Battery weight	4.6 kg
Sound level at driver's ear acc. to EN 12053	<70 dB(A)



Lithium-ion battery for increased productivity



Pin code for access control



Effortless manoeuvrability, light and compact



Ergonomic design perfect for confined areas

Distributor information