

Hand pallet truck 1.0 ton

BT lifter

H-series

HHM100I

HHL100I

HHL100PH

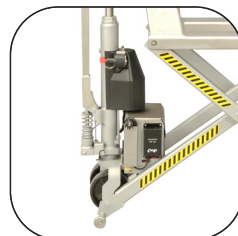

Hand pallet truck

Truck specifications					HHM100I	HHL100I	HHL100PH
Identification	1.1	Manufacturer			Toyota	Toyota	Toyota
	1.2	Manufacturer's type designation			HHM100I	HHL100I	HHL100PH
	1.4	Operator type			Hand	Hand	Hand
	1.5	Load capacity/rated load	Q(t)	kg	1000	1000	1000
	1.6	Load centre distance	c	mm	600	600	600
	1.8	Load distance, centre of drive axle to fork	x	mm	980	980	980
	1.9	Wheelbase	y	mm	1280	1280	1280
Weight	2.1	Service weight		kg	121	135	140
	2.2	Axle load, with load, drive/castor/fork wheel		kg	205/370	205/370	205/370
	2.3	Axle load, without load, drive/castor/fork wheel		kg	20/55	20/55	20/55
Wheels	3.1	Steer/fork wheel. Polyurethane (P) ¹⁾ , Nylon (N)			P/N	P/N	P/N
	3.2	Wheel size, front			175x60	175x60	175x60
	3.3	Wheel size, rear			75 x 75	75 x 75	75 x 75
	3.5	Wheels, number front/rear (x=driven wheels)			2/2	2/2	2/2
	3.6	Track width, front	b ₁₀	mm	152	152	152
	3.7	Track width, rear	b ₁₁	mm	410	410	410
Dimensions	4.4	Lift	h ₃	mm	710	710	710
		Lift height	h ₂₃	mm	800	800	800
	4.9	Height of towbar in drive position, min./max.	h ₁₄	mm	1280	1280	1280
	4.15	Height, lowered	h ₁₃	mm	90	90	90
	4.19	Overall length	l ₁	mm	1655	1655	1655
	4.20	Length to face of forks	l ₂	mm	465	465	465
	4.21	Overall width	b ₁ /b ₂	mm	560	560	560
	4.22	Fork dimensions	s/e/l	mm	50/160/1190	50/160/1190	50/160/1190
	4.25	Width over forks	b ₅	mm	560	560	560
	4.32	Ground clearance, centre of wheelbase	m ₂	mm	20	20	20
	4.34	Aisle width for pallets 800 x 1200 lengthways	A _{st}	mm	1845	1845	1845
4.35	Turning radius	W _a	mm	1525	1525	1525	
Electric motor	6.2	Lift motor rating at S3 15%		kW	—	0.9	0.9
	6.4	Battery voltage, nominal capacity K ₅		V/Ah	—	12/51	12/51
	6.5	Battery weight		kg	—	18	18

1) Powerthane wheel as steer wheel if equipped with handbrake.

All data are based on table configuration. Other configurations may give other values.

Truck performance and dimensions are nominal and subject to tolerances.

Toyota Material Handling products and specifications are subject to change without notice.

Dimensional drawings

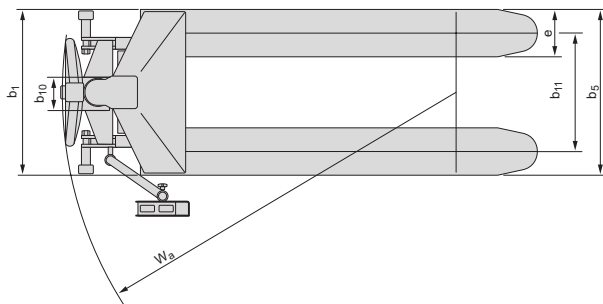
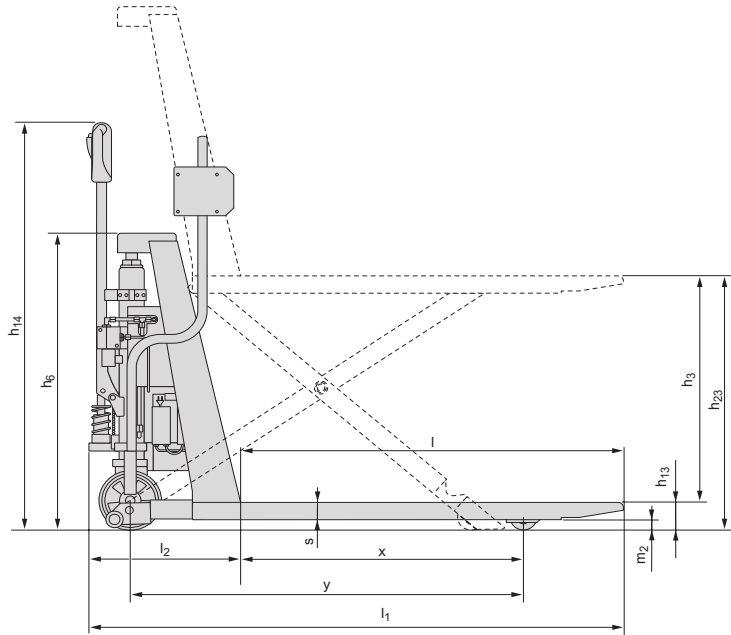
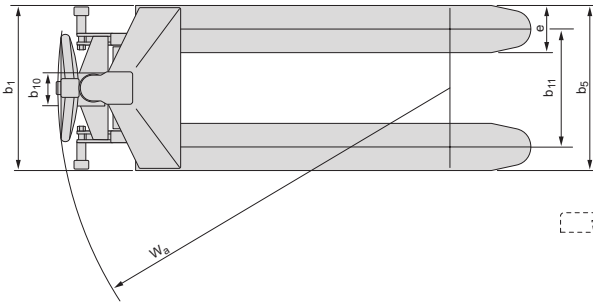
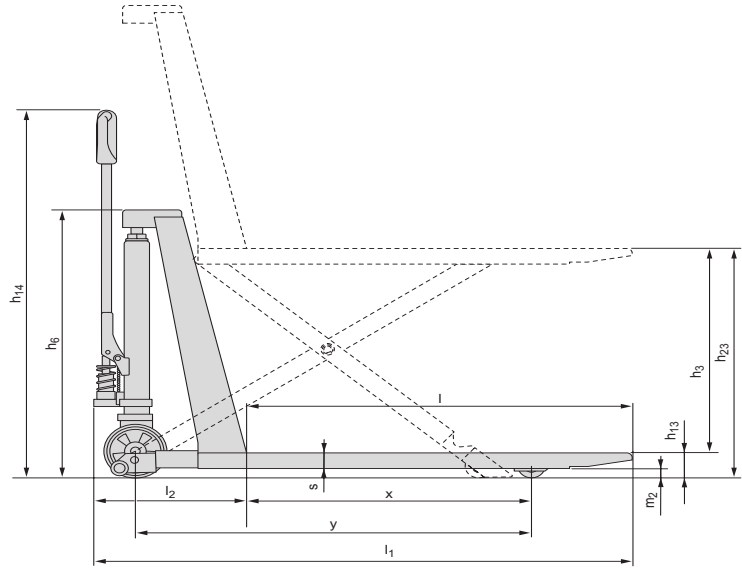

Truck features:

- BT Lifters H-series allow ergonomic handling of goods. The ergonomical working height, fully adjustable, is ideal for distribution, sorting operations or in a production environment.
- Maximum lift capacity 1000 kg, maximum lift height 810 mm. Short truck length provides narrow turning radius.
- Supporting clamps in front of the rollers reduce the risk of tipping forward.
- Adjustable stabilizers automatically brake, to ensure safety and stability in operation.
- Quicklift-function as standard with automatic transfer to normal lift with loads over 250 kg.
- HHM100I and HHL100I are stainless steel alternative of this truck model.
- The HHL100PH with photocell gives a smooth and controlled movement as the High Lifter lowers and raises automatically when goods are loaded or unloaded from the pallet.
- This product has been environmentally declared.

