

RCS20, 30, 40 Walkie CB Truck



RCS-series
RCS20
RCS30
RCS40

Dimensions and General Information

Specifications			RCS20	RCS30	RCS40
A	Tractor Width	In.(mm)	34.1 (866)	34.1 (866)	34.1 (866)
B	Tractor Head Length	In.(mm)	64.8 (1646)	70.1 (1781)	76.6 (1946)
C	Wheelbase	In.(mm)	47 (1194)	52.3 (1328)	58.6 (1488)
D	Grade Clearance	%	10	10	10
E	Tractor Underclearance	In.(mm)	2.1 (53)	2.1 (53)	2.1 (53)
F	Turning Radius	In.(mm)	56.7 (1440)	62.0 (1575)	68.3 (1735)
G	Battery Floor Height (with optional rollers)	In.(mm)	9.5 (241)	9.5 (241)	9.5 (241)
H	Battery Compartment (L x W)	In.(mm)	32.3 x 13.3 (820 x 337)	32.3 x 13.3 (820 x 337)	32.3 x 13.3 (820 x 337)
J	Overall Length (with 42" forks)	In.(mm)	106.8 (2713)	112.1 (2847)	118.6 (3012)
K	Tractor Height at Handle	In.(mm)	25.25 (641)	25.25 (641)	25.25 (641)
L	Tractor Height at Battery	In.(mm)	32.5 (826)	32.5 (826)	32.5 (826)
M	Handle Height (Retracted)	In.(mm)	55.6 (1412)	55.6 (1412)	55.6 (1412)
N	Top Vertical Braking Arc	Degree	12.5	12.5	12.5
O	Bottom Braking Arc	Degree	10.5	10.5	10.5
P	Handle Operating Arc	Degree	67	67	67
Q	Fork (H x W)	In.(mm)	1.5 x 4 (40 x 100)	1.5 x 4 (40 x 100)	1.5 x 4 (40 x 100)
R	Load Backrest (height)	In.(mm)	48 (1219)	48 (1219)	48 (1219)
S	Fork Adjustment	In.(mm)	8.5 – 30 (215 – 760)	8.5 – 30 (215 – 760)	8.5 – 30 (215 – 760)
T	Tilt (Forward)	Degree	3	3	3
T	Tilt (Backward)	Degree	8	8	8

Model		RCS20	RCS30	RCS40
Power Unit		24V, Single Drive	24V, Single Drive	24V, Single Drive
Max. Capacity	lb.(kg)	2,000 (907)	3,000 (1361)	4,000 (1814)
Drive Tire (Rubber)	In.(mm)	5 x 10.5 (127 x 267)	5 x 10.5 (127 x 267)	5 x 10.5 (127 x 267)
Load Wheels (Single, Poly)	In.(mm)	4 x 10.0 (101 x 254)	4 x 10.0 (101 x 254)	4 x 10.0 (101 x 254)
Fork Sideshift (Each Way)	In.(mm)	3 (76)	3 (76)	3 (76)

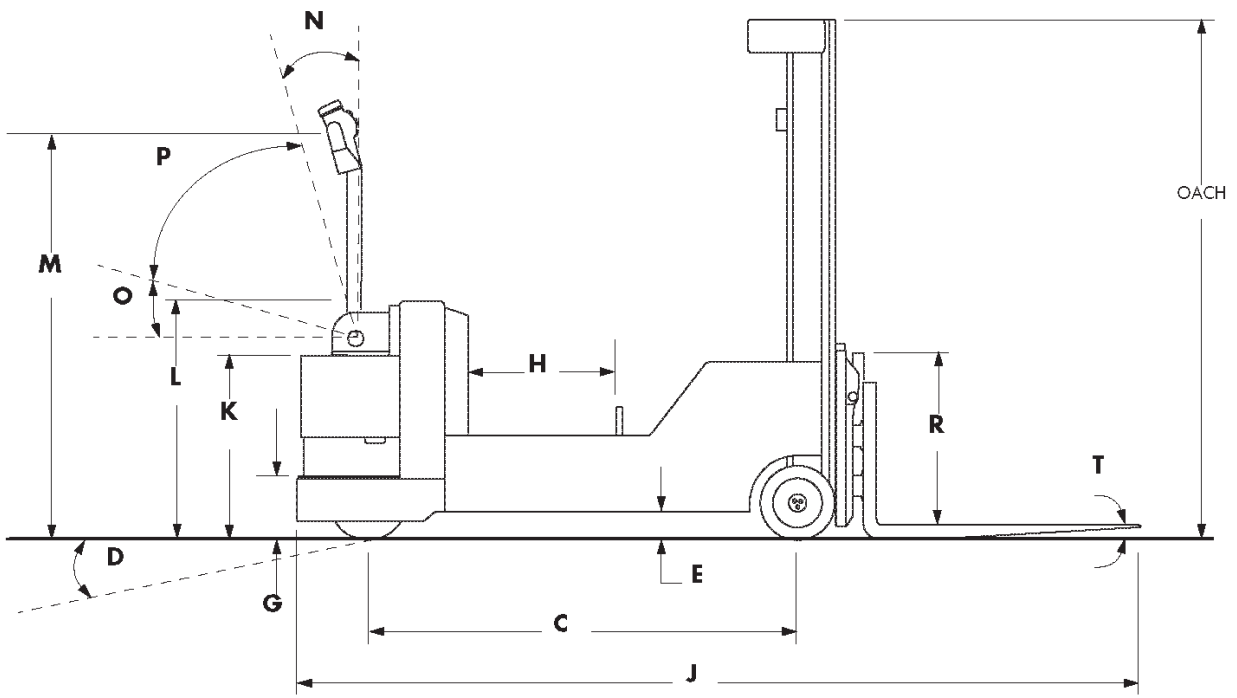
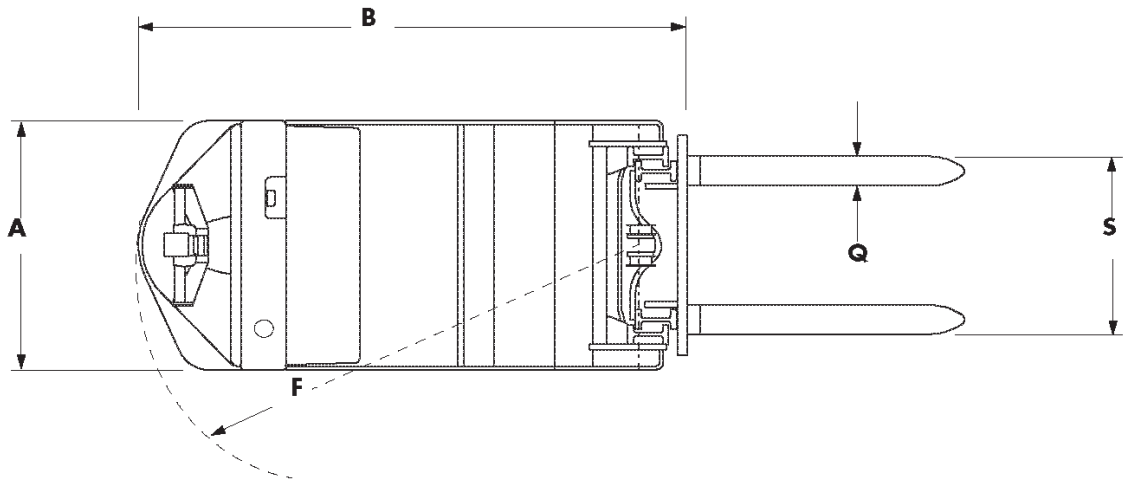

Mast Specifications	OACH [1]	Capacity @ 24 in. [600 mm] Load Center [4]	Elevated Height [2]	Extended Height [2]	Free Lift with Backrest [3]	Free Lift without Backrest [3]	Truck Weight without Battery
Model	in. (mm)	in. (mm)	in. (mm)	in. (mm)	in. (mm)	in. (mm)	lb.(kg)
RCS-C20TN	71 (1804)	2,000 (907)	104 (2641)	152 (3860)	12 (305)	12 (305)	3,600 [5] (1633)
	83 (2109)	2,000 (907)	128 (3251)	176 (4470)	12 (305)	12 (305)	3,600 [5] (1633)
	95 (2413)	2,000 (907)	152 (3860)	200 (5080)	12 (305)	12 (305)	3,600 [5] (1633)
RCS-C20TF	71 (1804)	2,000 (907)	104 (2641)	152 (3860)	23 (584)	50 (1270)	3,600 [5] (1633)
	83 (2109)	2,000 (907)	128 (3251)	176 (4470)	35 (889)	62 (1575)	3,600 [5] (1633)
	95 (2413)	2,000 (907)	152 (3860)	200 (5080)	47 (1194)	74 (1880)	3,600 [5] (1633)
RCS-C30TN	71 (1804)	3,000 (1361)	104 (2641)	152 (3860)	12 (305)	12 (305)	4,600 [5] (2087)
	83 (2109)	3,000 (1361)	128 (3251)	176 (4470)	12 (305)	12 (305)	4,600 [5] (2087)
	95 (2413)	3,000 (1361)	152 (3860)	200 (5080)	12 (305)	12 (305)	4,600 [5] (2087)
RCS-C30TF	71 (1804)	3,000 (1361)	104 (2641)	152 (3860)	23 (584)	50 (1270)	4,600 [5] (2087)
	83 (2109)	3,000 (1361)	128 (3251)	176 (4470)	35 (889)	62 (1575)	4,600 [5] (2087)
	95 (2413)	3,000 (1361)	152 (3860)	200 (5080)	47 (1194)	74 (1880)	4,600 [5] (2087)
RCS-C30TT	71 (1804)	3,000 (1361)	150 (3810)	198 (5030)	23 (584)	50 (1270)	4,600 [5] (2087)
	83 (2109)	3,000 (1361)	180 (4572)	228 (5792)	35 (889)	62 (1575)	4,600 [5] (2087)
	87 (2210)	3,000 (1361)	189 (4800)	237 (6020)	39 (991)	66 (1676)	4,600 [5] (2087)
RCS-C40TN	71 (1804)	4,000 (1814)	100 (2540)	148 (3760)	6 (153)	6 (153)	5,800 [5] (2631)
	83 (2109)	4,000 (1814)	124 (3149)	172 (4369)	6 (153)	6 (153)	5,800 [5] (2631)
	95 (2413)	4,000 (1814)	150 (3810)	198 (5030)	6 (153)	6 (153)	5,800 [5] (2631)
RCS-C40TT	71 (1804)	4,000 (1814)	150 (3810)	198 (5030)	23 (584)	50 (1270)	5,800 [5] (2631)
	83 (2109)	4,000 (1814)	180 (4572)	228 (5792)	35 (889)	62 (1575)	5,800 [5] (2631)
	87 (2210)	4,000 (1814)	189 (4800)	237 (6020)	39 (991)	66 (1676)	5,800 [5] (2631)

NOTES:

[1] Tolerance = +/-0.5 in. (+/-13 mm).

[2] Tolerance = +2.5/-0.5 in. (+64/-13 mm).

[3] Tolerance = +/- 1 in. (+/- 25.4 mm).

[4] Consult Sales Engineering for capacities with sideshift.

[5] Add 100 lb. (45.4 kg) with sideshift option.

Performance Specifications		RCS20		RCS30		RCS40	
		Unloaded	Loaded	Unloaded	Loaded	Unloaded	Loaded
Travel Speed	mph (km/h)	3.2 (5.1)	2.9 (4.6)	3.4 (5.4)	3.0 (4.8)	3.3 (5.3)	2.8 (4.5)
Lift Speed	fpm (m/s)	49 (0.24)	37 (0.18)	49 (0.24)	32 (0.16)	49 (0.24)	27 (0.13)
Lower Speed	fpm (m/s)	44 (0.22)	60 (0.31)	42 (0.21)	60 (0.31)	42 (0.21)	60 (0.31)
Tilt (Up/Down) Time	sec	3.0	4.0	3.0	4.0	3.0	4.0
Sideshift Time	sec	2.5	2.5	2.5	2.5	2.5	2.5

Battery Specifications		RCS20	RCS30	RCS40
Amperes, Max		650	650	650
Battery Connector Type		SB-175	SB-175	SB-175
Battery Connector Color		Red	Red	Red
Lead Location		B	B	B
Lead Length	in. (mm)	20 (508)	20 (508)	20 (508)
Maximum Usable Compartment Size (L x W x H)	in.(mm)	32.3 x 13.3 x open (820 x 337 x open)	32.3 x 13.3 x open (820 x 337 x open)	32.3 x 13.3 x open (820 x 337 x open)
Battery Weight, Maximum	lb.(kg)	1,375 (624)	1,375 (624)	1,375 (624)
Battery Weight, Minimum	lb.(kg)	950 (431)	950 (431)	950 (431)

Standard Equipment

- 24 Volt Battery, Power Unit
- Battery Compartment, 32.3 x 13.3" usable
- Brake, Deadman
- Carriage, Class II, 33.8" Wide, ITA
- Control Handle, Ergonomic
- Cushioned Mast Stops
- Directional, Reverse
- Electric Lift and Lower Switches in Control Handle
- Emergency Power Disconnect
- Emergency Reversing Switch
- Horn
- Hour Meter
- Key Switch
- Manual Lift and Lower Control on Chassis
- Mechanical Drum Brake
- Poly Load Wheels 10 x 4"
- Programmable Performance
- Thumb Wheel Throttle Controls
- Warranties, Asset Protection Standard Warranty Coverage Structural Extended Warranty

Available Options

- Battery Rollers With Dual Sidegates
- Cold Storage Conditioning
- Screen Guard
- Audible All Travel Alarm
- Pallet Centering Guide
- Gauge, Battery Discharge with Hour Meter
- Sideshift Carriage, 3" each way



TMHI1241380ARCS203040 - version 1, 1220

