

RRS30 Walkie Reach Truck



RRS-series
RRS30

Dimensions and General Information

Specifications		In.(mm)	RRS30
A	Tractor Width	In.(mm)	34.1 (866)
B	Tractor Head Length (2-stage/3-stage)	In.(mm)	47.4/50.6 (1204/1285)
C	Wheelbase	In.(mm)	55.3 (1405)
D	Grade Clearance	%	10
E	Tractor Underclearance	In.(mm)	2.1 (53)
F	Baseleg Underclearance	In.(mm)	2 (51)
G	Turning Radius	In.(mm)	65 (1651)
H	Battery Floor Height (with optional rollers)	In.(mm)	9.5 (241)
J	Battery Compartment (L x W)	In.(mm)	32.3 x 13.3 (820 x 337)
K	Overall Length (excluding forks)	In.(mm)	69.75 (1772)
L	BLO (Inside)	In.(mm)	32 – 50 (813 – 1270)
M	BLO (Outside)	In.(mm)	40 – 58 (1016 – 1473)
N	Tractor Height at Handle	In.(mm)	25.25 (641)
O	Tractor Height at Battery	In.(mm)	32.5 (825)
P	Handle Height (Retracted)	In.(mm)	55.6 (1412)
Q	Top Vertical Braking Arc	Degree	12.5
R	Bottom Braking Arc	Degree	10.5
S	Handle Operating Arc	Degree	67
T	Fork (H x W)	In.(mm)	1.75 x 4 (45 x 100)
U	Load Backrest (height)	In.(mm)	48 (1219)
V	Fork Adjustment	In.(mm)	12 – 30 (305 – 760)
W	Reach Distance	In.(mm)	24 (610)
X	Tilt (Forward)	Degree	3
X	Tilt (Backward)	Degree	4

		RRS30
Power Unit		24 Volt, Single Drive
Max. Cap. @ 24" [600 mm] Load Center	lb.(kg)	3,000 (1361)
Drive Tire (Poly)	in.(mm)	5 x 10.5 (127 x 267)
Load Wheels (Tandem, Poly)	in.(mm)	2.875 x 4 (73 x 102)
Fork Sideshift (Each Way)	%	2 or 3 (51 or 76)

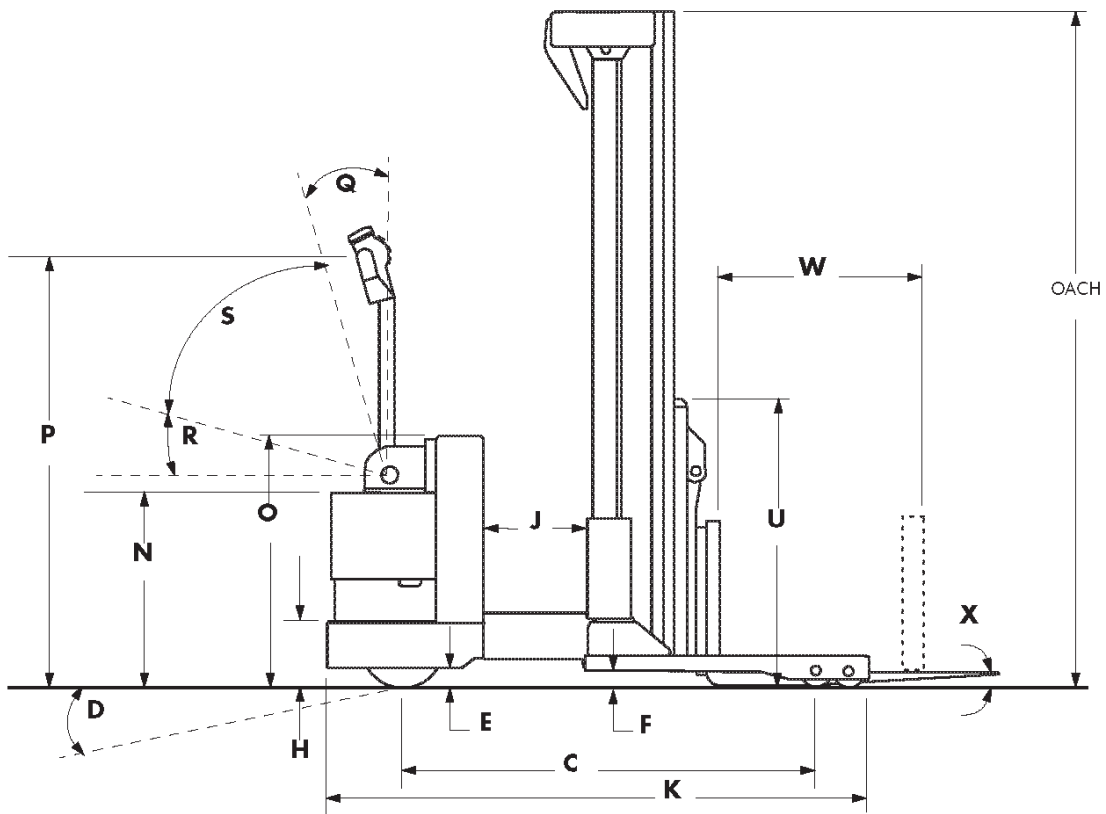
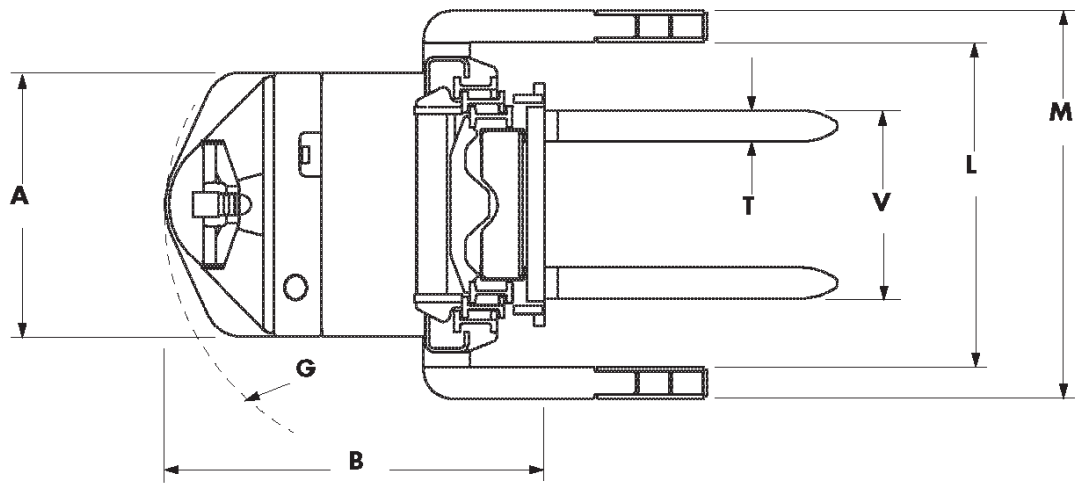

Performance Specifications		RRS30	
		Unloaded	Loaded
Travel Speed	mph (km/h)	3.2 (5.1)	2.8 (4.5)
Lift Time	fpm (m/s)	46 (0.23)	29 (0.15)
Lower Speed	fpm (m/s)	47 (0.24)	60 (0.31)
Reach/Retract Time	sec	4.0	4.0
Tilt (Up/Down) Time	sec	3.0	4.0
Sideshift Time	sec	2.5	2.5

Battery Specifications		RRS30
Amperes, Max		650
Battery Connector Type		SB-175
Battery Connector Color		Red
Lead Location		B
Lead Length	in.(mm)	20 (508)
Maximum Usable Compartment Size (L x W x H)	in.(mm)	32.3 x 13.3 x open (820 x 337 x open)
Battery Weight, Maximum	lb.(kg)	1,375 (624)
Battery Weight, Minimum	lb.(kg)	950 (431)

Mast Specifications	OACH [1]	Elevated Height [2]	Extended Height [2]	Free Lift with Backrest [3]	Free Lift without Backrest [3]	Truck Weight without Battery
Model	in. (mm)	in. (mm)	in. (mm)	in. (mm)	in. (mm)	lb. (kg)
RRS-R30TN	71 (1804)	100 (2540)	148 (3760)	6 (153)	6 (153)	3,400 (1542)
	83 (2109)	124 (3149)	172 (4369)	6 (153)	6 (153)	3,400 [4] (1542)
	95 (2413)	150 (3810)	198 (5030)	6 (153)	6 (153)	3,400 (1542)
RRS-R30TT	71 (1804)	150 (3810)	198 (5030)	23 (584)	36 (914)	3,400 (1542)
	83 (2109)	180 (4572)	228 (5792)	35 (889)	48 (1219)	3,400 (1542)
	87 (2210)	189 (4800)	237 (6020)	47 (1194)	60 (1524)	3,400 (1542)

NOTES:

[1] Tolerance = +/-0.5 in. (+/-13 mm).

[2] Tolerance = +2.5/-0.5 in. (+64/-13 mm).

[3] Tolerance = +/- 1 in. (+/- 25.4 mm).

[4] With 2-stage 83"/124" mast. Add 100 lb. (45.4 kg) with sideshift option.

Standard Equipment

- 24 Volt Battery, Power Unit
- Battery Compartment, 32.3 x 13.3" usable
- Brake, Deadman
- Brake, Mechanical Drum
- Carriage, Class II, 33.8" Wide, ITA
- Carriage Tilt 3° Forward/4° Back
- Control Handle, Ergonomic
- Directional, Reverse
- Electric Lift and Lower Switches in Control Handle
- Emergency Power Disconnect
- Emergency Reversing Switch
- Fixed Baselegs
- Horn
- Hour Meter
- Key Switch
- Manual Lift and Lower Control on Chassis
- Mast, Cushioned Stops
- Mast, Guard Polycarbonate
- Programmable Performance
- Tandem Poly Load Wheels 4 x 2.875"
- Thumb Wheel Throttle Controls
- Warranties, Asset Protection
 - Standard Warranty Coverage*
 - Structural Extended Warranty*

Available Options

- Battery Rollers With Dual Sidegates
- Cold Storage Conditioning
- Screen Guard
- Audible All Travel Alarm
- Pallet Centering Guide
- Gauge, Battery Discharge with Hour Meter
- Sideshift Carriage, 3" each way



TMH11240462A RRS30 - version 1, 1220

