

# RSS22, 30, 40 Walkie Straddle Truck



*RSS-series*  
RSS22  
RSS30  
RSS40

# Dimensions and General Information

Specifications		In.(mm)	RSS22	RSS30	RSS40
A	Tractor Width	In.(mm)	34.1 (866)	34.1 (866)	34.1 (866)
B	Tractor Head Length (2-stage/3-stage)	In.(mm)	38.4/43.6 (975/1107)	42.7/47.9 (1082/1217)	44.7/47.9 (1135/1217)
C	Wheelbase	In.(mm)	51.1 (1298)	55.4 (1407)	55.4 (1407)
D	Grade Clearance	%	10	10	10
E	Tractor Underclearance	In.(mm)	2.1 (53)	2.1 (53)	2.1 (53)
F	Baseleg Underclearance	In.(mm)	2 (51)	2 (51)	2 (51)
G	Turning Radius	In.(mm)	60.8 (1544)	65.1 (1654)	65.1 (1654)
H	Battery Floor Height (with optional rollers)	In.(mm)	9.5 (241)	9.5 (241)	9.5 (241)
J	Battery Compartment (L x W)	In.(mm)	32.3 x 9 (820 x 228)	32.3 x 13.3 (820 x 337)	32.3 x 13.3 (820 x 337)
K	Overall Length	In.(mm)	67 (1702)	71.3 (1811)	71.3 (1811)
L	BLO (Inside)	In.(mm)	32 – 50 (813 – 1270)	32 – 50 (813 – 1270)	32 – 50 (813 – 1270)
M	BLO (Outside)	In.(mm)	40 – 58 (1016 – 1473)	40 – 58 (1016 – 1473)	40 – 58 (1016 – 1473)
N	Tractor Height at Handle	In.(mm)	25.25 (641)	25.25 (641)	25.25 (641)
O	Tractor Height at Battery	In.(mm)	32.5 (826)	32.5 (826)	32.5 (826)
P	Handle Height (Retracted)	In.(mm)	55.6 (1412)	55.6 (1412)	55.6 (1412)
Q	Top Vertical Braking Arc	Degree	12.5	12.5	12.5
R	Bottom Braking Arc	Degree	10.5	10.5	10.5
S	Handle Operating Arc	Degree	67	67	67
T	Fork (H x W)	In.(mm)	1.5 x 4 (40 x 100)	1.5 x 4 (40 x 100)	1.75 x 4 (45 x 100)
U	Load Backrest (height)	In.(mm)	48 (1219)	48 (1219)	48 (1219)
V	Fork Adjustment	In.(mm)	8.5 – 30 (215 – 760)	8.5 – 30 (215 – 760)	8.5 – 30 (215 – 760)

		RSS22	RSS30	RSS40
Power Unit		24V, Single Drive	24V, Single Drive	24V, Single Drive
Max. Cap. @ 24" [600 mm] Load Center	lb.(kg)	2,200 (997)	3,000 (1361)	4,000 (1814)
Drive Tire (Poly)	in.(mm)	5 x 10.5 (127 x 267)	5 x 10.5 (127 x 267)	5 x 10.5 (127 x 267)
Load Wheels (Tandem, Poly)	in.(mm)	2.875 x 4 (73 x 102)	2.875 x 4 (73 x 102)	2.875 x 4 (73 x 102)
Fork Sideshift (Each Way)	in.(mm)	2 or 3 (51 or 76)	2 or 3 (51 or 76)	2 or 3 (51 or 76)

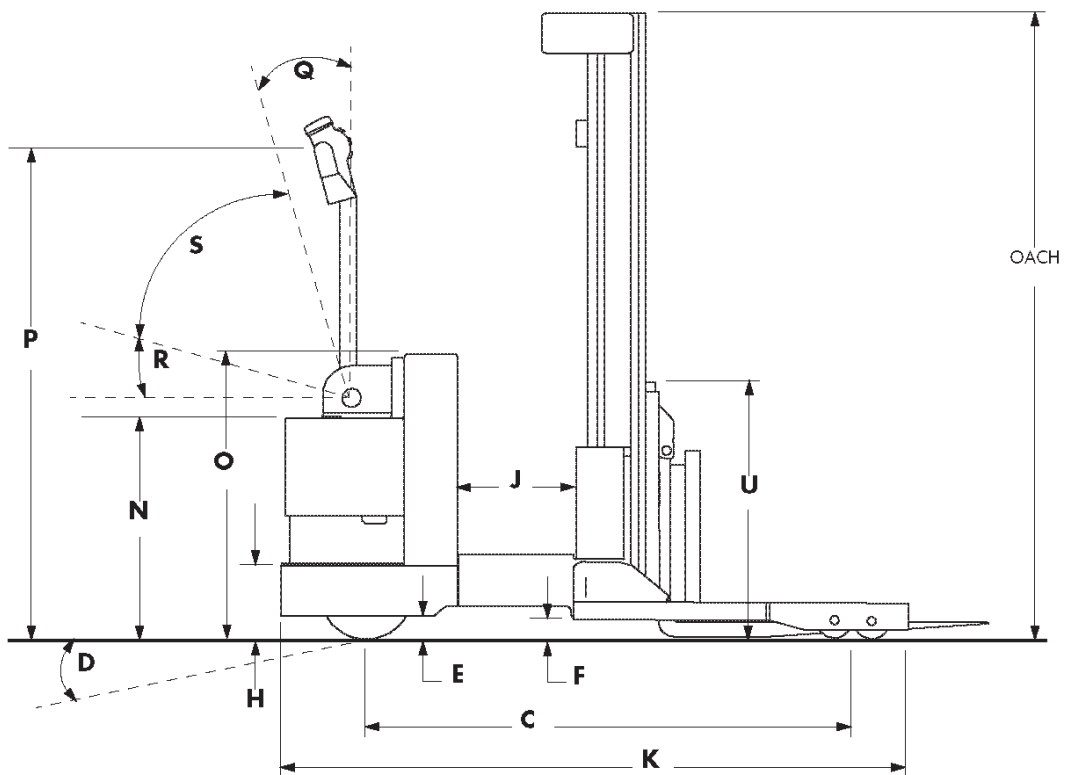
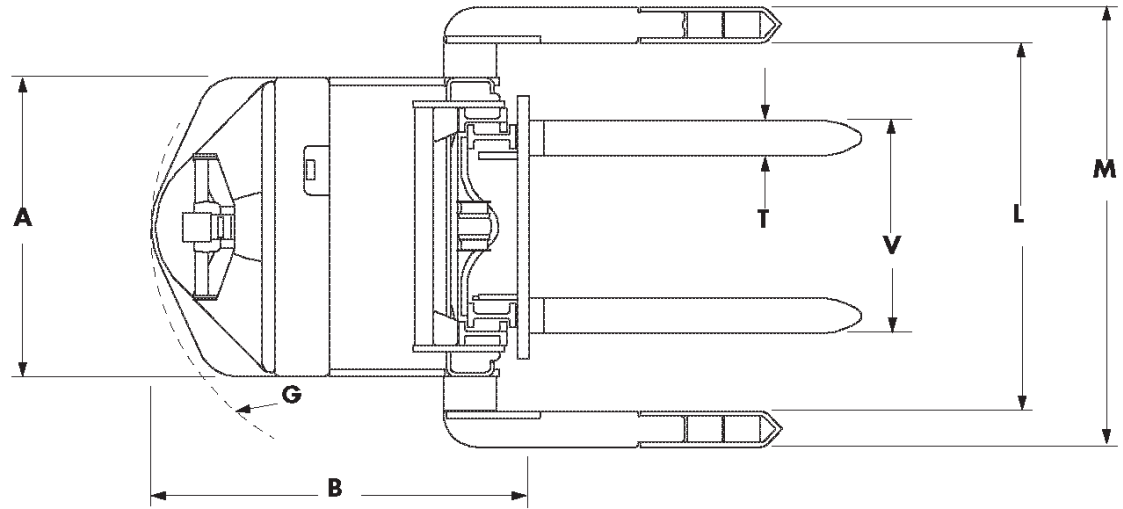

Performance Specifications		RSS22		RSS30		RSS40	
		Unloaded	Loaded	Unloaded	Loaded	Unloaded	Loaded
Travel Speed	mph (km/h)	3.3 (5.3)	2.9 (4.6)	3.3 (5.3)	2.9 (4.6)	3.2 (5.1)	2.6 (4.1)
Lift Time	fpm (m/s)	49 (0.24)	32 (0.16)	49 (0.24)	32 (0.16)	49 (0.24)	27 (0.14)
Lower Speed	fpm (m/s)	42 (0.21)	60 (0.31)	42 (0.21)	60 (0.31)	42 (0.21)	60 (0.31)

Battery Specifications		RSS22	RSS30	RSS40
Amperes, Max		330	650	650
Battery Connector Type		SB-175	SB-175	SB-175
Battery Connector Color		Red	Red	Red
Lead Location		B	B	B
Lead Length	in.(mm)	20 (508)	20 (508)	20 (508)
Maximum Usable Compartment Size (L x W x H)	in.(mm)	32.3 x 9.0 x open (820 x 228 x open)	32.3 x 13.3 x open (820 x 337 x open)	32.3 x 13.3 x open (820 x 337 x open)
Battery Weight, Maximum	lb.(kg)	980 (445)	1,375 (624)	1,375 (624)
Battery Weight, Minimum	lb.(kg)	300 (136)	950 (431)	950 (431)

Mast Specifications	OACH [1]	Capacity@ 24 in. [600 mm] Load Center [4]	Elevated Height [2]	Extended Height [2]	Free Lift with Backrest [3]	Free Lift without Backrest [3]	Truck Weight Without Battery
Model	in. (mm)	lb. (kg)	in. (mm)	in. (mm)	in. (mm)	in. (mm)	lb. (kg)
RSS-S22TN	71 (1804)	2,200 (997)	104 (2641)	152 (3860)	12 (305)	12 (305)	2,450 [5] (1111)
	83 (2109)	2,200 (997)	128 (3251)	176 (4470)	12 (305)	12 (305)	2,450 [5] (1111)
	95 (2413)	2,200 (997)	152 (3860)	200 (5080)	12 (305)	12 (305)	2,450 [5] (1111)
RSS-S22TT	71 (1804)	2,200 (997)	150 (3810)	198 (5030)	23 (584)	50 (1270)	2,450 [5] (1111)
RSS-S30TN	71 (1804)	3,000 (1361)	104 (2641)	152 (3860)	12 (305)	12 (305)	2,585 [5] (1173)
	83 (2109)	3,000 (1361)	128 (3251)	176 (4470)	12 (305)	12 (305)	2,585 [5] (1173)
	95 (2413)	3,000 (1361)	152 (3860)	200 (5080)	12 (305)	12 (305)	2,585 [5] (1173)
RSS-S30TT	71 (1804)	3,000 (1361)	150 (3810)	198 (5030)	23 (584)	50 (1270)	2,585 [5] (1173)
	83 (2109)	3,000 (1361)	180 (4572)	228 (5792)	35 (889)	62 (1575)	2,585 [5] (1173)
	87 (2210)	3,000 (1361)	189 (4800)	237 (6020)	39 (991)	66 (1676)	2,585 [5] (1173)
RSS-S40TN	71 (1804)	4,000 (1814)	100 (2540)	148 (3760)	6 (153)	6 (153)	2,840 [6] (1288)
	83 (2109)	4,000 (1814)	124 (3149)	172 (4369)	6 (153)	6 (153)	2,840 [6] (1288)
	95 (2413)	4,000 (1814)	150 (3810)	198 (5030)	6 (153)	6 (153)	2,840 [6] (1288)
RSS-S40TT	71 (1804)	4,000 (1814)	150 (3810)	198 (5030)	23 (584)	50 (1270)	2,840 [6] (1288)
	83 (2109)	3,600 (1633)	180 (4572)	228 (5792)	35 (889)	62 (1575)	2,840 [6] (1288)
	87 (2210)	3,500 (1588)	189 (4800)	237 (6020)	39 (991)	66 (1676)	2,840 [6] (1288)

**NOTES:**

[1] Tolerance = +/-0.5 in. (+/-13 mm).

[2] Tolerance = +2.5/-0.5 in. (+64/-13 mm).

[3] Tolerance = +/- 1 in. (+/- 25.4 mm).

[4] With 2-stage 83"/124" mast. Add 100 lb. (45.4 kg) with sideshift option.

---

## Standard Equipment

- 24 Volt Battery, Power Unit
- Battery Compartment (RSS22 only) - 32.3 x 9" usable
- Battery Compartment (RSS30 and RSS40 only) - 32.3 x 13.3" usable
- Brake, Deadman
- Brake, Mechanical Drum
- Carriage, Class II, 33.8" Wide, ITA
- Control Handle, Ergonomic
- Directional, Reverse
- Electric Lift and Lower Switches in Control Handle
- Emergency Power Disconnect
- Emergency Reversing Switch
- Fixed Baselegs
- Horn
- Hour Meter
- Key Switch
- Manual Lift and Lower Control on Chassis
- Mast, Cushioned Stops
- Mast, Guard Polycarbonate
- Programmable Performance
- Tandem Poly Load Wheels 4 x 2.875"
- Thumb Wheel Throttle Controls
- Warranties, Asset Protection
  - Standard Warranty Coverage*
  - Structural Extended Warranty*

## Available Options

- Battery Rollers With Dual Sidegates
- Cold Storage Conditioning
- Screen Guard
- Audible All Travel Alarm
- Pallet Centering Guide
- Gauge, Battery Discharge with Hour Meter
- Sideshift Carriage, 3" each way



TMHI1240463ARSS223040 - version 1, 1220

